

TOYS

*To aid life, leaving it free however to unfold itself, that is the basic task of the educator.*

— Maria Montessori, M.D.

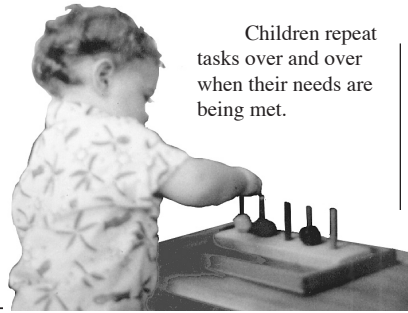

Children repeat tasks over and over when their needs are being met.

SELECTING TOYS

When picking out a toy for a child, imagine just what she will do with it. Does it invite purposeful activity? Decision making? Imagination? For how long will my child play with it? Will it encourage the child to explore, to spend time with it? There are many wonderful wooden or cloth imaginative toys available to children but often what is missing is a choice of toys with purpose. These toys lay

**Note:** Every toy in this section has a unique purpose and draws on a unique mental and physical ability of the developing child, especially eye-hand coordination and the developing hand. Although all are suitable for the home, many are made for constant use in Infant Communities. This quality is reflected in the price. Sometimes children younger than one year will be ready for these items, under supervision.

THREE MEN IN A TUB ON A ROCKING BASE

This simple toy provides further challenge: putting the "men" dowels into the holes as the base may rock. A simple favorite, this classic first peg toy is made of beautiful oil-rubbed hardwood. The base is 4.5" long and the pegs are 2.25" tall. From the USA.

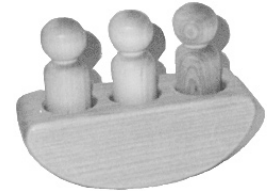

BT15 \$14.50

THICK AND THIN PEGS

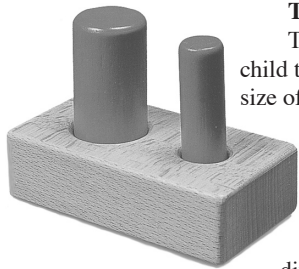

This is the first toy for the child to compare visually the size of the peg and hole, and to learn to place pegs in matching holes. Because the pegs are held by the whole hand, the child will learn to actually feel the difference in thick and thin as he experiences it visually. Later,

after experience, the words *thick* and *thin* can be taught. The natural, solid wood base is approximately 4.5" x 2.25, the painted red pegs are 3" tall. Made in England.

BT800 \$29.00

BOX WITH ROUND DISCS AND SQUARE DISCS

TWO COMPLETE TOYS, ACTIVITIES, ABILITIES.

This finely-crafted hardwood box gives the child practice with eye-hand coordination as he places the 2-inch round wooden discs into the slot on the top— like coins in a piggy bank. Then he reaches into the open front and retrieves the discs to repeat the activity. There are no lids to lift or slide, and the task is easy for the child to repeat over and over. The box comes with six round wooden discs.

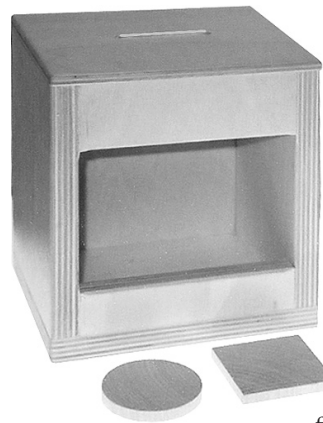

A more advanced work is made possible with 2-inch square discs. Unlike the round discs which fit into the slot no matter how the child holds them, the squares need to be exactly lined up with the opening to put them through. Made of Baltic birch plywood, 6.5" tall, the top is 6" x 4.75". From the USA.

CT035 Box with 6 round discs \$52.00  
 CT037 Package of 6 extra round discs \$4.00  
 CT039 Package of 6 square discs \$4.00

PEGBOARDS

This series of three wooden pegboards takes the child from the very first whole-hand grasped cylinders, to a different grasp of fingers.

The child can decide where to put which color of peg, making patterns that can change.

He progresses from fitting three small wooden pegs into matching holes—to a rearranging, by color patterns, nine peg-figures in the largest pegboard.

With each pegboard there is an equal number of red, blue, and yellow pegs. The smallest, three-peg board is 7" x 2.5" and the largest is 7" square. The pegs are 2.5" tall. The pegboards are made in England.

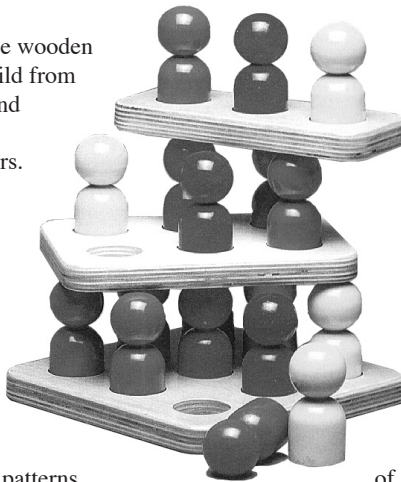

of

BT330 3-Peg Board \$33.00  
 BT336 6-Peg Board \$48.00  
 BT339 9-Peg Board \$64.00

JUMBO CYLINDER 25-PEG PLAYBOARD

Pegboards teach children to use visual discrimination to figure out which shape fits in which hole. This puzzle, even though at first a very simple task—put the round cylinder in the round hole—offers further exploration of sorting by height and color. The cylinders can be put in the board in an amazing variety of patterns. Later show him how to make towers with the cylinders.

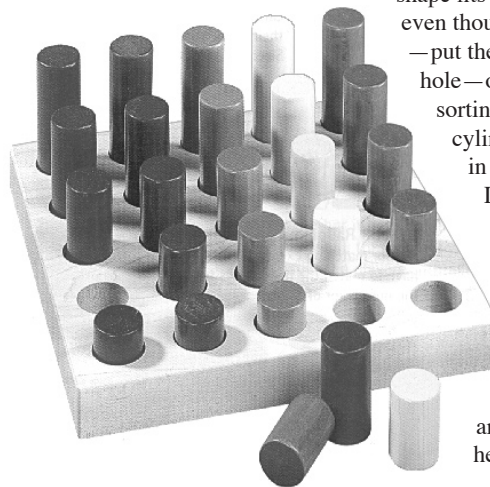

There are five sets of graduated cylinders, red, blue, yellow, green, and orange. The playboard is a solid hardwood board, 10" x 10". The cylinders are graduated from 1.75" to 4" in height. Made in Germany.

CT044 \$51.00

## AGE 1-3 - TOYS

the foundation for richer work of the imagination.

Imagination is a wonderful tool of humans, but it cannot be created out of nothing. Creative imagination is based on, and directly related to, the quality of sensorial experiences in the real world. A rich imagination enables one to picture a solution (solving a puzzle

for example) and to work toward it. The more experience a child has with real purposeful activity and solving problems, the more useful, creative, and effective her imagination will become.

We have selected, or created, manipulative toys that have a wide variety of challenges. For most of them there is a beginning and an end, and the

completion of the activity is inherent in the material. For example when the child has put all of the discs in the *box with discs*, she has successfully completed a cycle of activity, feels a great deal of satisfaction, and is often ready to repeat the activity.

Eye-hand coordination is developed when it is obvious that a toy goes

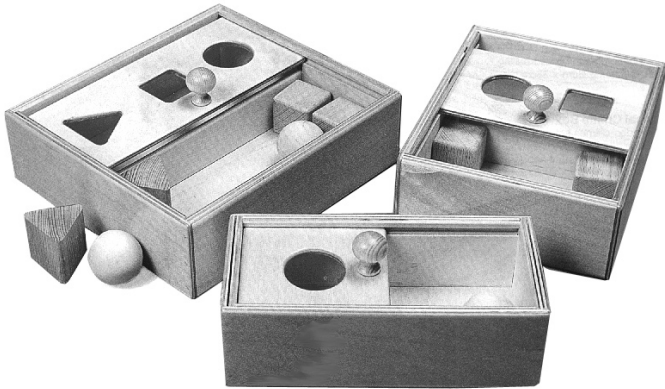

### MINI SORTING BOXES

Easily manipulated by the very youngest child who will now work with both hands, Mini Sorting Boxes give a graduated first experience of matching the square, triangular and circular three-dimensional wooden objects with the holes that match, and the further challenge of dropping them into the box—excellent for eye-hand coordination. The sliding lids are permanently attached, which makes it easy for the child to repeat the activity over and over without any help from the adult. The smallest box, is 8" long, 4" wide and 3" tall. The largest is 8.5" long, 8" wide and 3 inches tall. Baltic birch plywood, made in England.

CT28	1-Shape Sorting Box	\$64.00
CT282	2-Shape Sorting Box	\$78.00
CT284	3-Shape Sorting Box	\$92.00

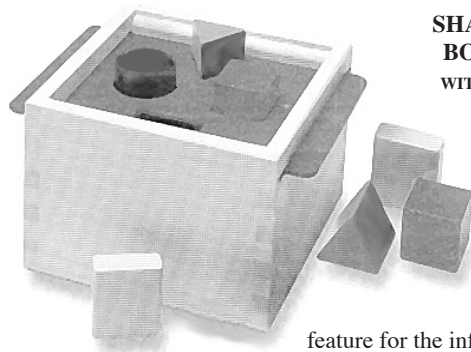

### SHAPE SORTING BOX WITH SLIDING LID

#### WITH SLIDING LID

We examine and test every sorting box that comes on the market to find the best for children.

An important feature for the infant's independent work is the permanently attached lid which slides back and forth, but doesn't come all the way out.

The lid has four holes—round, triangular, square, and rectangular.

The box is natural wood and the sliding lid stained a soft red. The measurements are 5.5" x 5.5", height 4." Made in Germany.

CT30		\$39.00
------	--	---------

### SHAPE SORTING BOX WITH FIVE LIDS

This beautiful shape-sorting box is really five toys in one, and is built to last for years. The large hardwood box comes with five different lids to match the ability of the child, and covers several different levels of visual discrimination of shapes, and eye-hand coordination. When the solid shape is dropped through the hole in the top, the child must grasp the large knob and open the drawer to get it out of the box, and this entails using hands together.

The lids and the front of the drawer are red; the rest of the box is a natural wood. The base is 7.5" x 7.5", and the height 4.3". One box, five lids, nine solid wood pieces—three each of sphere, triangular prism, and cube. The suggested order of the use of the lids is (1) one round hole, (2) one triangular hole, (3) one square hole, (4) 2 holes, (5) 3 holes. Baltic birch plywood, made in England.

CT29	\$166.00
------	----------

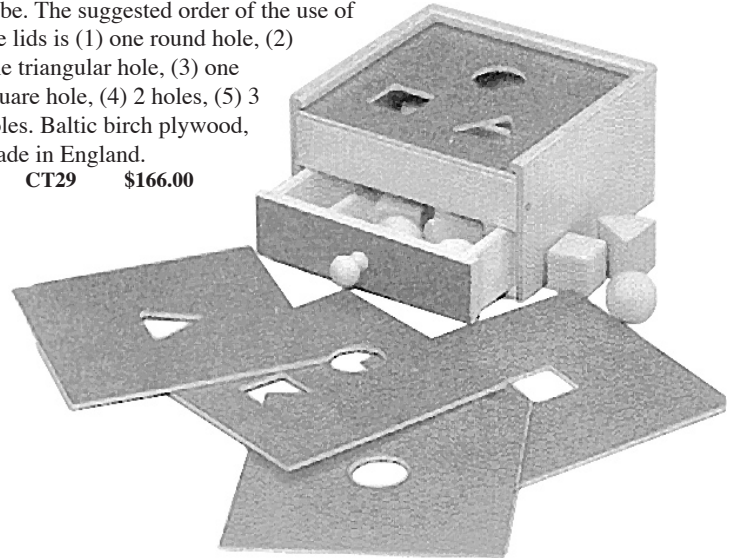

### SHAPE SORTER

This *shape sorter* toy is the easiest, and also the most challenging, of this kind of toy. This is because it can be presented to the child in three stages: (1)

give her the four 3-dimensional shapes (*cylinder, cube, rectangular prism, triangular prism*—yes, soon she will learn the correct names!)

to place in the indentations on the 7" square wooden base. (2) give her the four square wooden pieces that fit over these solid figures (3)

give her the two rectangular pieces that fit over 2 each of the solid figures. Voila!

These three stages might be accomplished the same day, or over a period of weeks. *Follow the child.* Made in Thailand.

(*) CT055	\$22.00
-----------	---------

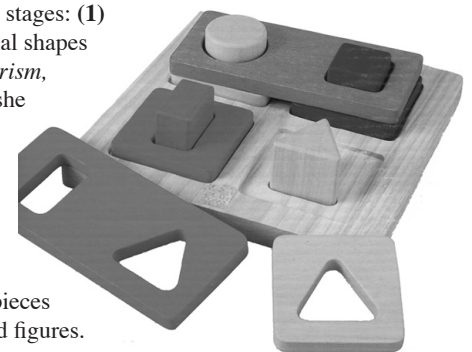

together in a particular way, for example a cube in a square hole and a sphere in a round hole.

It is no small thing for a child to learn to direct her muscles to do what her eyes see should be done. And the challenge of such activities helps the child develop coordination and concentration. All of this must be

considered when selecting toys for the child at this developmental stage.

The use of wood instead of plastic helps the child appreciate the natural world, the colors, shades and grains of wood, and the varying weight of wooden toys in a variety of sizes and densities. Quality shows a respect for the child and teaches the child respect for belongings.

Beauty and durability are important at all ages for the child's tastes are being formed at this time of life.

People who learn to appreciate living with beauty early in life can more easily lead us in creating a beautiful home, and perhaps a beautiful world, when they grow up.

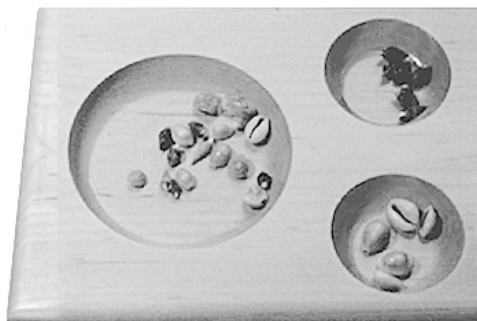

### FIRST SORTING TRAY

Sorting is a satisfying human mental process at any age, and the need to carry out this activity begins very early. With this small sorting tray the adult places, for example, 5 each of two kinds of large nuts in the large well, and the child sorts them into the two smaller wells. You can use large buttons, large shells, many other things found in the home. Made in California of natural hardwood, 7" square.

CT010

\$33.00

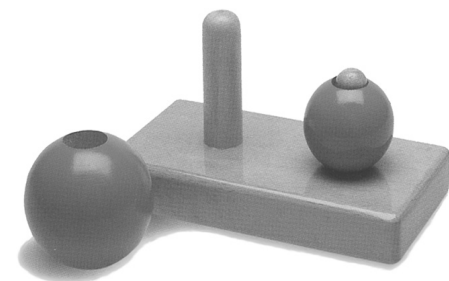

### LARGE & SMALL BALLS ON POSTS

This simple toy gives the child the first experience of fitting a bead or other object over and around a dowel. The child will feel the difference of *large* and *small* at the same time she sees the difference, and later learn the language *large* and *small*. The two colored (green) spheres or balls are 1.5" and 2" in diameter, and the solid natural wood base is 5" x 2", 3/4" tall. Made in England.

CT630

\$30.00

### STACKING/NESTING TRAYS

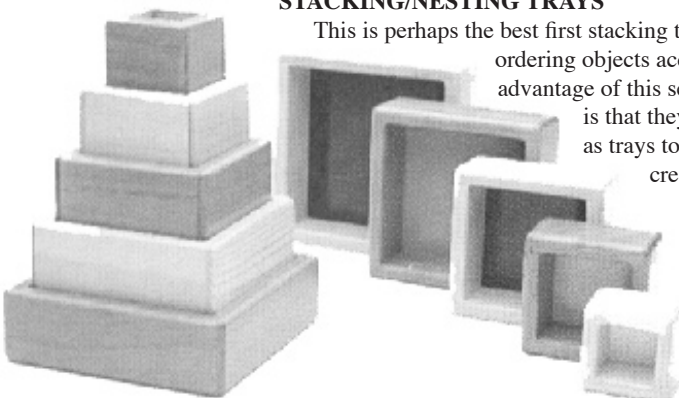

This is perhaps the best first stacking toy, providing practice in ordering objects according to size. The added advantage of this set of stacking/nesting toys is that they can be used individually as trays to hold other materials, or creatively with block play.

They can be nested in several different ways, inside each other or as a tower, standing tall, or on their sides. This a good first exercise in visual discrimination of graduated sizes. They are made of natural wood

with brightly colored bottoms. The tower of five, when stacked one on top of the other, is 9" tall. The largest tray is 6.5" wide, and the smallest tray is 2.25" wide. Made in the USA.

CT36

\$47.00

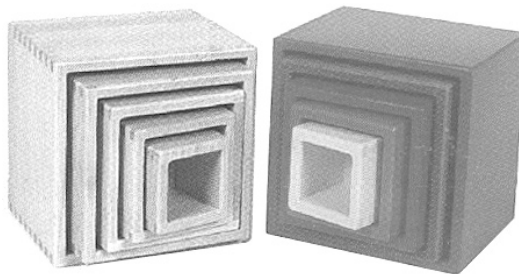

### NESTING BOXES

Children between the age of one and three delight in putting things in boxes and other containers. They also begin to be interested in comparing and sorting objects by size and putting them in order—a function of the mathematical mind. *Nesting boxes* satisfy this drive, and allow for creative play, making towers, and eventually combined with other blocks for a variety of structures. They are made from beech and maple wood, exclusively from the annual tree fall in European forests. The corners are dovetailed and all edges are rounded. The *natural* nesting blocks are finished so that the wood grain shows, and the *colored* nesting blocks are each a different color: blue, green, red, orange and yellow. The largest block is 5.25" x 5.25" x 4.5", and the smallest 2" x 2" x 2". Made in Germany.

CT140 Natural Nesting Blocks

\$52.00

CT150 Colored Nesting Blocks

\$62.00

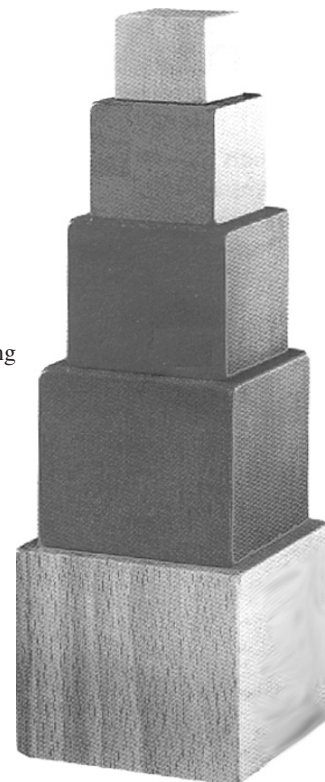

## ORGANIZING AND ROTATING TOYS

Toys should be kept in the area where the family lives, not only in the child's room. We do not recommend the traditional large toy boxes where pieces can get lost and toys not found.

Shelves are much more satisfying, where toys are kept always in the same place. Having order in the environment

creates a feeling of security in the child, and trust in the environment. Baskets, trays, or small boxes neatly arranged on low shelves can be very helpful in creating this order.

Watch your child to see which toys he plays with most and which ones just get dropped and forgotten. Try to keep only as many toys available to the child

as can be kept neat, and uncrowded, in baskets on a shelf.

## LEARNING TO PUT TOYS AWAY

Limiting the number of toys available at any one moment, and having a place for every toy, helps with the task of teaching the child to put toys away. But most important is the example set by



### MINI RING THREADER

This toy calls forth a new challenge, a new way to use the wrist and hand, and is one of the first given to a child in the Montessori Infant Community. The knob on the end of the dowel keeps the rings in place so that the child can lift them off instead of sliding them—a further challenge.

Made of Baltic birch plywood, the natural wood base is 8" x 8.5", 7" tall. The three painted wooden rings, one in each of the primary colors (red, blue, yellow) are 3" in diameter. Made in England.

CT625 \$78.00

### BEAD THREADING

Bead threading is a skill related to the toys on this page. With two different kinds of beads, this is an excellent first bead stringing

set containing twelve discs 2" in diameter, twelve 1.25" beads, and a threading cord with a wooden dowel attached for ease in stringing. The beads are in primary and secondary colors. Made in the USA.

CT02 \$22.00

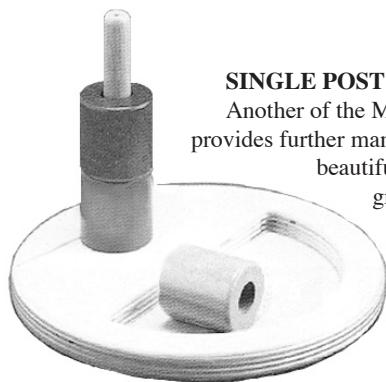
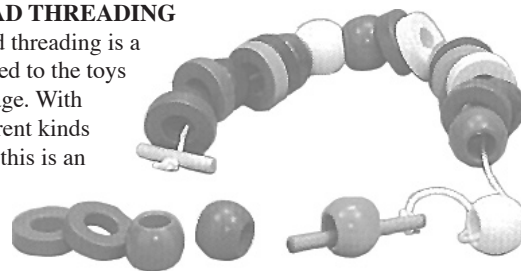

### SINGLE POST & TRAY

Another of the Montessori Infant Community exercises provides further manipulative practice. This is the most beautiful stacking toy we have seen, and its graceful base, with an indentation to hold the cylinders, inspires focused work. There are three cylinders painted bright primary colors. They fit onto a vertical dowel which is carefully rounded at the top. A very satisfying piece of work for the young child. Baltic birch plywood,

Height 5," tray 6.5" in diameter, made in England.

CT37 \$52.00

### TRIPLE POST ABACUS & TRAY

This toy follows the single post abacus and tray. It gives the child further practice, not only in placing objects on the dowels, but in sorting and making patterns.

There are three natural wood dowels on a natural wood base and tray made of Baltic birch plywood, three 1.3" cubes (red, blue and yellow), three spheres (red, blue, and yellow) and three cylinders (red, blue, and yellow) so the child can sort by shape or by color, or make her own pattern. Height 5,5"; tray 9" x 7.7". Made in England.

CT700 \$89.00

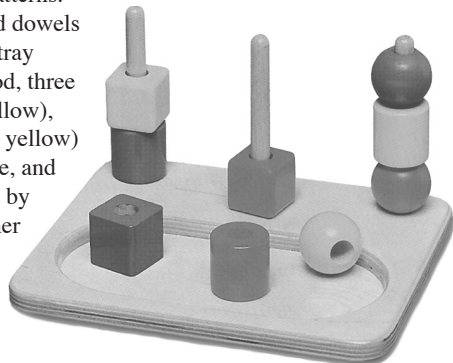

### KUGEL ABACUS

This is a larger and more advanced stage of abacus. The dowels are the same natural wood as the base so the child has to sort out which beads to place where by the length of the dowel and the number of beads. These beads can also be used for variety with *bead threading*. The base is 10" x 2.5" and the tallest dowel is 9" long. The "one" bead is natural wood, the "two" green, "three" yellow, "four" blue, and "five" red. Made in Germany.

CT220 \$40.00

## AGE 1-3 - TOYS

the others in the environment. If the adult carefully and continually puts the pieces of puzzles or toys back, with a smile, in front of the child, she will eventually imitate this activity. Sometimes the "putting away" into baskets is the most enjoyable part of play at this age. In a Montessori infant community this lesson is much easier than in the home because

the teacher's job is to model for the child all day long. She will constantly put things away, carefully, slowly, and as the child becomes aware of this he naturally wants to learn to do this—just as he wants to learn everything else adults do.

It is much easier to get into the habit of putting a toy away when it is obvious where it goes on the shelf, each

toy having a "place." It is more difficult when all of the toys are being played with at once, and all the shelves empty, so it helps to get into the habit of putting a toy away before getting out another—again, the adult does this and is eventually imitated by the child. The parent can make a game of "putting away" instead of thinking of it as a distasteful chore.

### THREADING CATERPILLAR & COLOR GAME

We thought this was just a good threading toy until our 2-year-old grandson asked what the colored die was for, and then proceeded to play the game! He enjoyed the process of matching the color of the die to the disc as much as the threading.

The game can be played with more people taking turns throwing the die and "building" the caterpillar. Roll the die, if the color red comes up on the top of the die, pick up and thread a red bead, if blue comes up on top thread a blue one, and so on. Three wooden discs in each of the primary and secondary colors. Discs 1.25" in diameter. Made in Germany.

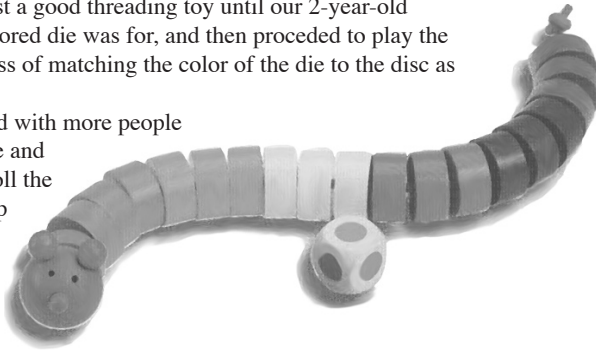

CT390

\$26.00

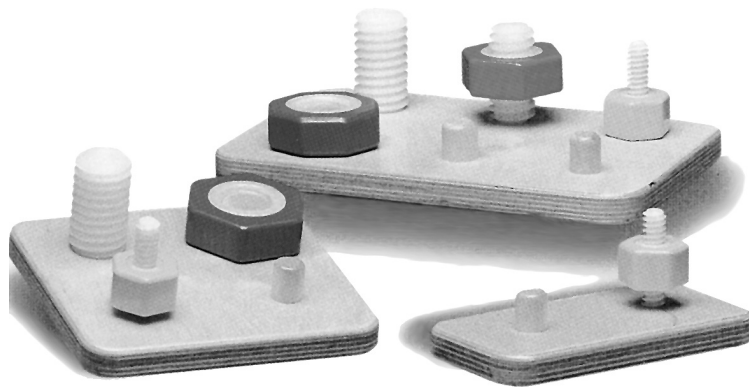

### NUTS AND BOLT BOARDS

These three toys aid in the development of wrist action as well as eye-hand coordination and visual discrimination of sizes. With the first, smallest 1-bolt board the child removes the bolt from the wooden peg where it is kept, places it on the white plastic nut and screws it on. With the second and third boards he must match the size of bolt to nut, using a different grip for each size, and then screw the bolt on the nut. At the end of the work the child unscrews each bolt and places it back on the wooden holding post before putting it away.

Size of bases: 1-bolt board is 6" x 3" (yellow bolt); 2-bolt is 6" x 6" (yellow and blue bolts); 3-bolt is 6" x 9" (blue, yellow, red bolts) 5/8" thick. Made in England.

CT710 1-Bolt Board	\$39.00
CT712 2-Bolt Board	\$68.00
CT714 3-Bolt Board	\$99.00
CT716 Bolt Boards/3	\$199.00



### SEW'N'SEW

A larger version of this folk toy was originally used to teach children to sew. We find this (2.5 inches tall) one even better.

It is easier for the child to hold while he threads the attached cord and wooden "needle" (the thickness of a pencil) through the holes in many different ways. In the beginning a child will need help to unthread so that he can begin again . . . and again, but he will soon figure it out for himself.

This is an excellent toy for eye-hand coordination and concentration. Made in China for an American company.

DT24

\$9.50

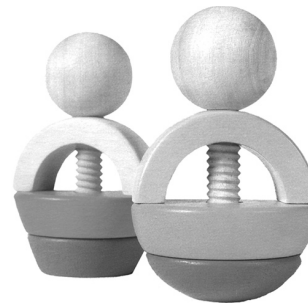
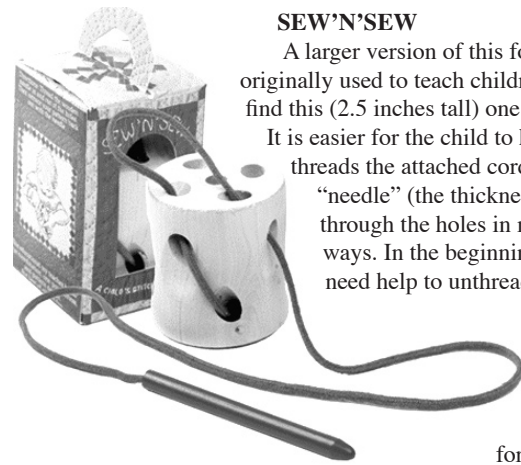

### NUTS AND BOLTS

In this challenging toy the child gets practice turning both wrists in opposite directions and at the same time is introduced to the physics principle of the inclined plane. There are two wooden "bolts" and six nuts that screw onto the bolts in a variety of ways. The length of the configurations in this illustration are 5" and 6." Made in Thailand.

CT111

\$19.00

**RESPECTING CONCENTRATION**

One of the most important things we can do for a child is to respect concentration. When the child is engaged in something safe and purposeful (an activity requiring effort of both the mind and body—not watching TV!) this is considered an important *work*, to be respected and protected—to be cherished.

*The first essential for the child's development is concentration. It lays the whole basis for his character and social behavior. Praise, help, or even a look, may be enough to interrupt him, or destroy the activity. It seems a strange thing to say, but this can happen even if the child merely becomes aware of being watched. After all, we too sometimes*

*feel unable to go on working if someone comes to see what we are doing.*

*The teacher's [and parents'] skill in not interfering comes with practice, like everything else, but it never comes very easily. What advice can we give to mothers? Their children need to work at an interesting occupation: they should not be helped unnecessarily, nor interrupted, once they have begun to do something intelligent.*

—Dr. Maria Montessori

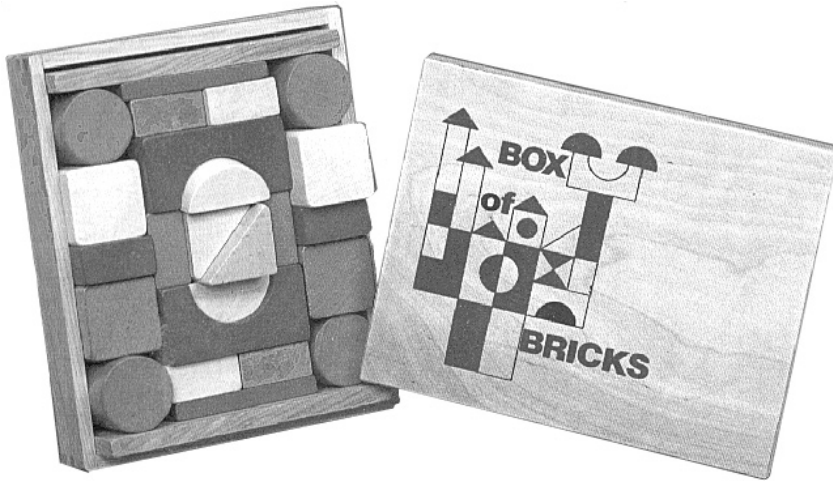

**BOX OF BRICKS**

This set of blocks ("bricks" in England) will be a favorite for many years—beautiful, good quality, fun to put away, and easy to pack up and take along on trips. The very young child enjoys learning to put things in a box and close the lid.

We recommend giving the number of blocks in the beginning that will make it easy for the child to do this. As the child grows he will enjoy learning to put the bricks back in the box in a pattern—there are only a few ways to fit all of the blocks into the box so that the lid can be closed. There are 30 natural wood and colored blocks in many different shapes. The box is 10.25" long, 8.25" wide, 2" tall, made of hardwood. Made in England.

CT068 \$48.00

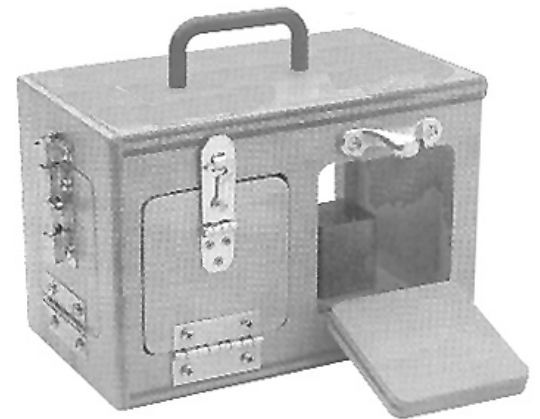

**SMALL LOCKS BOX**

This is the best practice box for learning to figure out and manipulate locks that we have seen. There are two separate compartments in this wooden box, and children really enjoy using the different locks to open the doors and find out what is inside!

In Montessori infant communities locks like these are used in several places in the environment. You might like to add locks like these to a child's cupboard in the kitchen, or in the bedroom—for real practice. There are six different locks all together—six ways to lock and unlock in all! The doors are fastened to the box by strong brass hinges. 9.3" x 5", height 5.5". Made in the USA.

CT081 \$70.00



**TINY TRIKE**

This indoor-outdoor push-along version of the traditional tricycle is very good for developing balance and coordination of the right and left sides of the body and for giving the child practice in using her large muscles.

*Tiny trike* is made of wood with tubular steel handles, vinyl grips, and sturdy plastic wheels and can be used inside or outside. The frame is 18" x 16.5" x 15", the wheels are 5" in diameter. Made for the American company *Radio Flyer* in China.

CT486 \$86.00